

# SPECIFICATION FIRE RATED VERTICAL PANELS

**FRL -/120/120**

## SCOPE OF WORK

The subcontractor shall be required to supply Glass Block Technologies International accredited labour, or similar approved persons, and Glass Block Technologies International proven materials for the successful erection of glass block panels to comply with all specifications and drawings related to this project. This will include the complete Ezylay Mortar System (for fire rated panels) or equal and glass blocks that reach the standard as set below and installed in accordance with CSIRO Opinion FCO-3301 Rev D. Complete test reports, opinions and drawings are available on request and ensured confidentiality.

## STANDARD

Fire Resistant Level of -/120/120 in accordance to AS 1530.4-2014 – Methods for fire tests on building materials, components, and structures Part 4: Fire Resistance Tests of elements of building construction.



## COMPLIANCE CERTIFICATE

Upon completion, Glass Block Technologies will issue a signed and dated compliance certificate stating the Fire Resistance Class, Standard and Test numbers, for submission to the relevant building inspectorate. All Fireproof glazing will be issued with Fire Tags to verify conformity.

*\*\*\*\* Please note: Glass Block Technologies will only issue compliance certificate if installing the complete fire rated system. Certificate should be supplied by installer/contractor.*

**NB: If a Compliance Certificate and fire tags are not issued – then the panel may be deemed as non-compliant.**

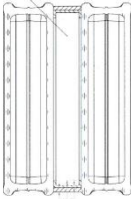
## MATERIALS - GLASS BLOCKS

Manufacturer:	Vitrablok s.r.o Bílinská 782/42 – 419 01 Duchcov – Česká republika
Model:	1919/13 120F
Size:	190x190x128mm – 2 glass blocks face thickness 4 x 7.0mm connected around the entire perimeter by a fiberglass U-shaped frame and glued together. Cavity between blocks filled with fire-resistant hydrogel.  
Pattern:	Wave (Only Pattern) *
Colour:	Neutral
Finish:	Clear / Sandblasted **

\* Block Patterns can be found at [www.glassblockconstruction.com](http://www.glassblockconstruction.com)

\*\* Sandblasted one side or both sides

According to European commission for construction products No. 305/2011, Vitrablok, s.r.o. declares that the construction product is in conformity with standard stated by harmonised norm EN 1051-1:2003. The construction product is safe when used for buildings of non-bearing constructions. The evaluation of conformity was performed according to EN 1051-2.

Vitrablok, s.r.o. production of glass blocks for the building industry and internal decoration has established and applies Quality Management System to be in accordance with the requirements of the standard ISO 9001:2015.

# SPECIFICATION FIRE RATED VERTICAL PANELS

**FRL -/120/120**



## Physical properties - Properties of Standard 190x190x128mm 120F Glass Block

<u>Essential Characteristic</u>	<u>Performance</u>	<u>Harmonised Technical specification</u>
Fire Resistance Level (AS 1530.4-2014)	FRL -/120/120	
Reaction on fire	Euroclass A1	EN 13501-1
Resistance to temperature differences	30 K	EN 1051-2
Mechanical resistance (compressive strength)	> 8 MPa	EN 1051-1
Sound insulation	43 dB	EN 717-1 EN 140-3
Thermal insulation (U)	1.6 Wm <sup>-2</sup> K <sup>-1</sup>	EN 673
Light Transmission:		
Clear	69%	EN 410
Sandblasted (one side)	60%	
Sandblasted (two sides)	51%	
Solar energy characteristics (g):		
Clear	64%	EN 410
Sandblasted (one side)	57% / 63%	
Sandblasted (two sides)	56%	
Solar Reflecting foil	41%	
Sandblasted (one side) – solar reflecting foil	40%	

\* First value is determined for radiation incidence onto non-sandblasted surface, second onto sandblasted one.

## FIRE RATED SYSTEM ACCESSORIES

### Ezylay Aluminium Frames

Extruded Aluminium designed specifically for the installation of glass blocks. Frame comprised of sections GBT-024 – Ezylay Fire Angle and GBT-031 – Ezylay Fire Frame 130mm

### Ezylay Mortar System Connectors

Registered designed and patented. Made from High Density, new material plastic (not recycled).

Connectors are used to achieve uniform joints by locating the glass blocks in a uniform manner while the mortar is curing. The connectors also hold the reinforcing rods in optimum position for maximum strength.

### Ezylay Premix Mortar - Standard

Ezylay Glass Block Premix Mortar is designed specifically for use with the Ezylay Glass Block Installation system. Schlegel Laboratories have tested the premix mortar in conjunction with the Ezylay System, Test number WA 141-90169. Ezylay Premix Mortar has also undergone compressive tests through NATA approved BGC Cemtech. The results were comparable to AS 2350.11.

### Dynabolt® Plus Round Head Anchors

10mm dia x 75mm length, M10, Zinc coated anchors.

Ezylay Frame drilled and fixed into non-cracked masonry and/or concrete at 400mm centres for concrete constructions, 12mm dia x 75mm length, M10, Zinc coated anchors.

### Bent Expansion Ties

Expansion Ties - C.G.T.1.B. are used to tie the Glass Block panels to surrounding construction allowing the panel to expand and contract.

### Promaseal® IBS™ Foam or Equal – Fire Resistant Foam

Flexible strip fire protection for joints and gaps, successfully tested to Australian Standard AS 1530 part 4 for periods of up to 4 hours depending on application. Cut to 10mm x 83mm x 2000mm (thickness x width x length).

### 6mm dia galvanised or Stainless steel reinforcing rods

<u>Max. Height x Max. Width</u>	<u>Surrounding Perimeter joint</u>	<u>Horizontal Joint</u>	<u>Vertical Joint</u>
3m x not fire limited	2	2	2

### Promaseal® Acrylic Sealant or Equal

Flexible water based gunnable sealant for fire resistant sealing of joint and service penetrations for up to 2 hours FRL when tested to AS1530 part 4.

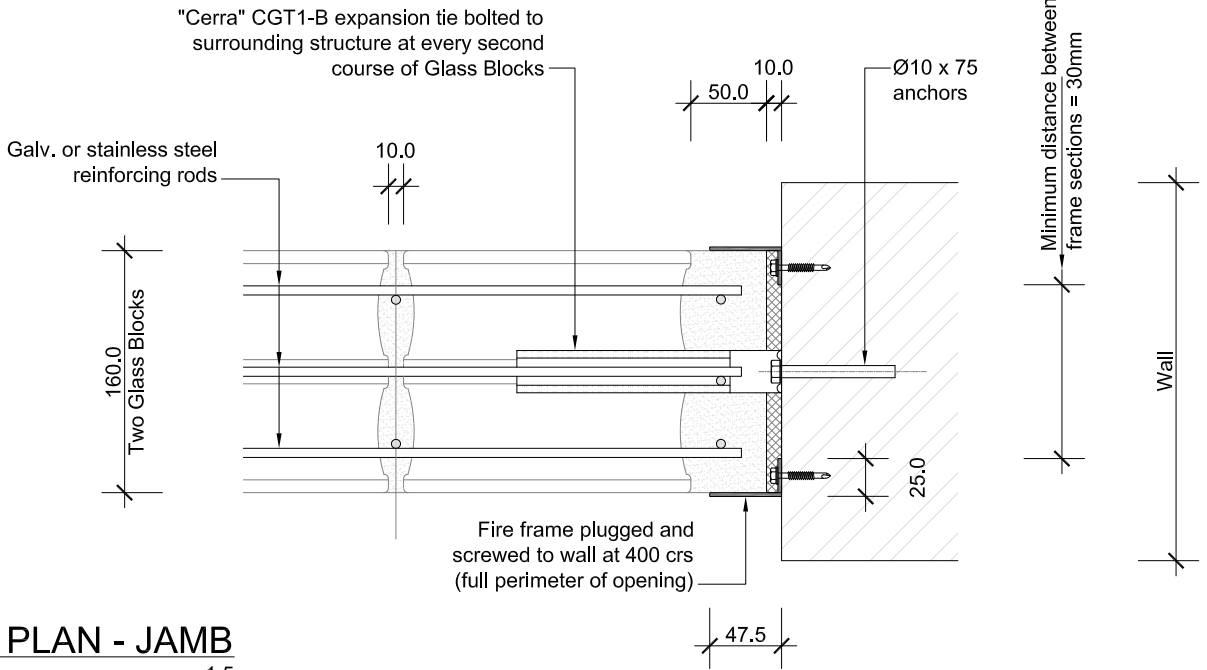

PLAN - JAMB  
1:5

**Note: The surrounding structure must meet the relevant FRL for the intended application**

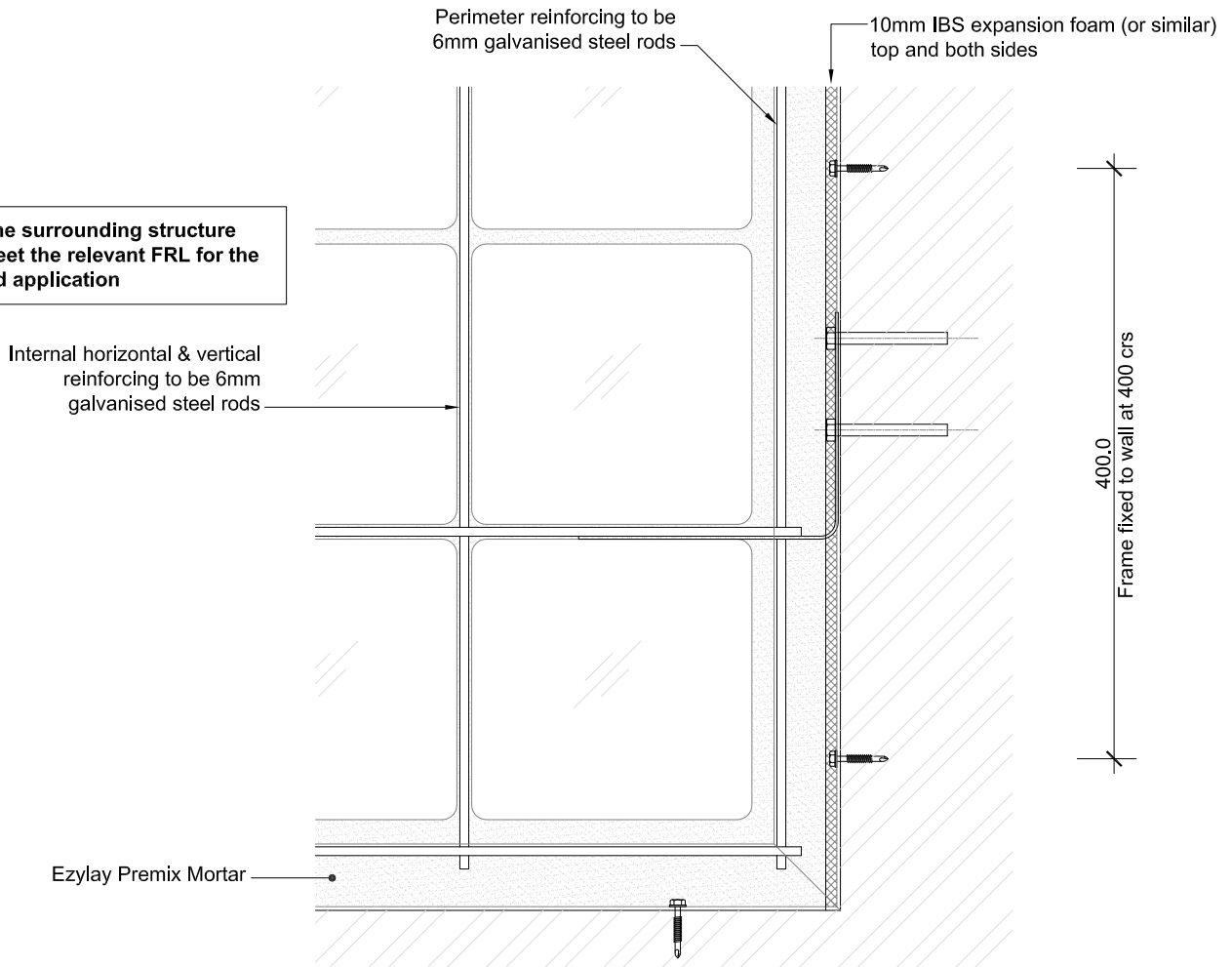

ELEVATION - JAMB & SILL  
1:5

**TITLE:**  
FIRE RATED DETAIL  
FOR FRL -/60/60 AND -/90/90

SCALE:	DATE:	DRAWN:	DRAWING NO.:
1:5	MARCH 2018	ADR	218004

 **Glass Block Technologies**  
International Pty Ltd



SHOWROOM & HEAD OFFICE: 777 MARSHALL ROAD, MALAGA WA 6090

TEL: 08 9248 8590

FAX: 08 9248 8591

www.glassblocktechnologies.com

© EZYLAY GLASS BLOCK SYSTEMS PTY LTD ACN 065 056 608 A.T.F. THE EZYLAY UNIT TRUST